



2025 - 2026

SINCE
1968

▶ ADS Laminaire

Air Dépoussiéré Stérile Laminaire

More than **50**^{ANS}

ADS Laminaire
Air Dépoussiéré Stérile Laminaire

GENERAL CATALOG

ULTRA CLEAN SOLUTION

Protection
of User

Product

Environment



www.adslaminaire-usa.com



info@adslaminaire.com



Download the
general
documentation





*The technical characteristics and dimensions of our equipment can be modified without notice according to the evolutions.
The photographs and diagrams in this catalog are not contractual.*

CONTENTS

● PRESENTATION

Commercial organization	6
Company presentation	7

● EQUIPMENT

	Decision tree	8
BIO-SAFETY CABINETS	BIO-PURE	10/11
	OPTIMALE	12
	BIOII	13
	PPS	14
CLEAN AREAS	CYTO-PURE	15
	PS / MS	16
	PS(X) / EQL	17/18
	SBM	19/20
VERTICAL FLOW	VFL	21
	UNIVERS MV	22
	MINISPACE	23
	IV GEL SPACE	24
	V	25
HORIZONTAL FLOW	OPTIGEL	26
	OPTIMUM	27
FUME HOODS	BCS	28
	T	29
FAN FILTER UNITS	FANJET	30
	FLOW'R-PURE	31
	CONVOYAIR	32
	SURPRESSEUR	33
EXTRACTOR HOODS	PROTEC I	34
	POWDERJET	35
	MINIPURE	36
	C-PURE	37
	UNIVERS MAV	38
	AD	39
	LAM	40
AIR SHOWER	AIR SHOWER	41
VARIOUS	GLOVE BOX	42
	Extraction fans	43
	Storage box /Furniture	44/45
	LED SLAT	46

● OUR SERVICES

	Utilities / Consumables	47
FILTERS	Flow Air Filters After	48
	Sales Services	49
	TINY S + VENTUM	50

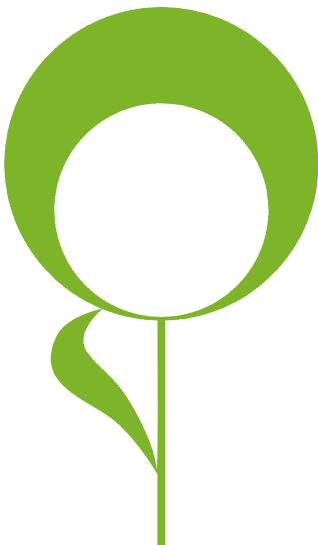

RESEARCH & DEVELOPMENT

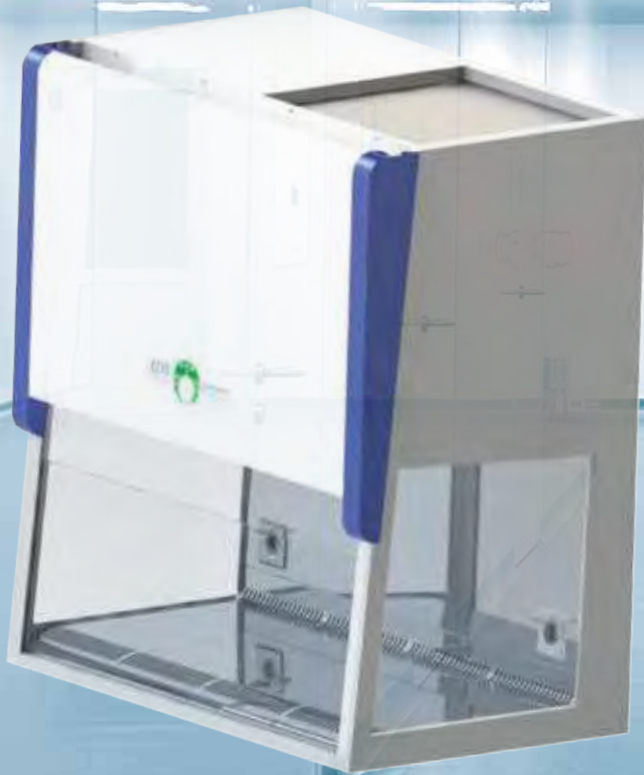

ADS
air dépoussiéré

34, rue Maurice de Broglie
21 Les Miroirs
88100 AULHAY-SOUS-BOIS FRANCE



Laminaire
stérile Laminaire

www.adsaeroindex.com
E-Mail: info@adsaeroindex.com
USA: www.adsaeroindex-usa.com



**EQUIPMENTS
& SERVICES**

Commercial Director (United States)

Mendy NARBONI (917) 600 8556
mendy.narboni@adslaminaire.com
1165 ST JOHNS PL#2A, BROOKLYN, NY 11213



Commercial Director (France)

Thomas PETITJEAN - 06 60 57 51 24 / 01 48 17 85 21
E-mail : thomas@adslaminaire.com

Sedentary Sales Representatives

Carine FONTAINE - 01 48 17 85 22 / 06 62 91 10 74
E-mail : carine@adslaminaire.com
Derya BULUT – 01 48 17 85 27
E-mail : derya.bulut@adslaminaire.com

Consumables / Utilities

Derya BULUT – 01 48 17 85 27
E-mail : derya.bulut@adslaminaire.com

Air Filtration

Ruben TAIEB - 06 99 04 40 03

Accounting

Nathalie BERNARD - 01 48 17 85 18
E-mail : compt@adslaminaire.com

Export / logistics

Warda LOUADJED - 01 48 17 85 29
E-mail : warda.louadjed@adslaminaire.com

Export / CEE

Bernard BUJAOUI
E-mail : bernard@adslaminaire.com

Morocco (Rabat agency)

Reda JBILOU +212 6 61 38 27 57
E-mail : reda.jbilou@adslaminaire.com

Quality manager

Carine VOITURIER - 01 48 17 85 16
E-mail : carine.voiturier@adslaminaire.com

After Sales Service

Nora HASSAINE - 01 48 17 85 12
E-mail : nora.hassaine@adslaminaire.com
Mélanie FAURE - 01 48 17 85 10
E-mail : melanie.faure@adslaminaire.com

Design Office

Eric FITOUSSI - 01 48 17 85 20
Loukman MOHAMED - 01 48 17 85 17
E-mail : loukman.mohamed@adslaminaire.com

Workshop / Delivery / Installation

Yannick MAILLY - 06 60 30 74 78
E-mail : yannick.mailly@adslaminaire.com

ADS LAMINAIRE designs, manufactures and commercializes laminar flow equipment since 1968.

It was the first French company specialized in this field.

A family-owned company on a human scale, it very quickly counted among its customers big names in the high-tech industry and was able to make its mark on the international market.

In order to propose a complete offer to its customers, ADS LAMINAIRE developed in parallel other activities and that since 1973, in the marketing of a range of consumables and utilities in clean environment.

In 1981, ADS started manufacturing and marketing air filters.

In 2009, ADS opened a commercial structure in Chicago to cover the American market.

In 2022, ADS opened an agency in Rabat, Morocco

The after-sales service, in charge of maintenance but also of controls and validations, has the capacity to intervene quickly on the whole French and European territories.

Over the years, ADS Laminaire has acquired a certain notoriety thanks to its experience, but also thanks to the quality and seriousness of its achievements and the various services it offers to its customers.

Certifications & Standards

Certified ISO 9001 : 2015 , since 2008 for the activities of:

Design, manufacture, sale, maintenance and control of controlled dust and laminar flow enclosures, chemical hoods and distribution of filters and utilities for cleanrooms

NF 095 label since 1997

ISO 14 644 standard:

Definition and Classification of Particulate Air Pollution.

Standard NF EN 12469:

Biotechnology: performance criteria for microbiological safety cabinets

Standard EN 1822-1:

Very high efficiency air filters and
Very low penetration air filters (HEPA and ULPA)

ISO 16690 standard:

Standard NF EN 12128:

Research, Development and Analysis Laboratory

Standard XPX 15-203 / EN 14175:

Laboratory fume hood

Standard NFX 15-211:

Recirculating fume hood



HOW TO SELECT YOUR HOOD ?

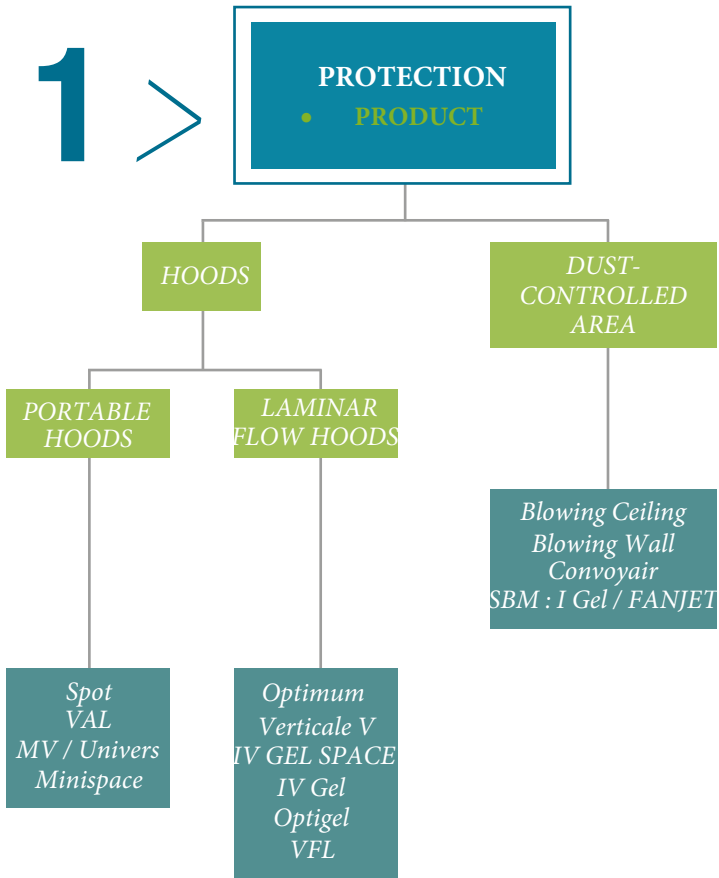

2 >

PROTECTION
• OPERATOR

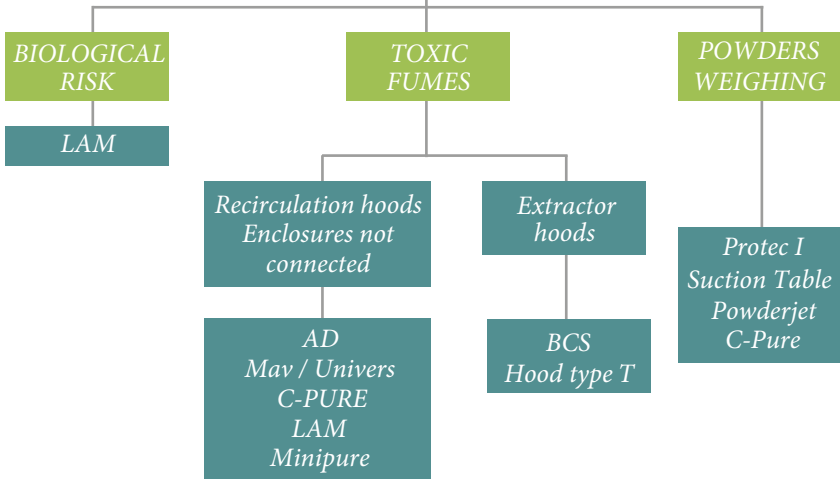

3 >

PROTECTION
• PRODUCT
• OPERATOR
• ENVIRONMENT

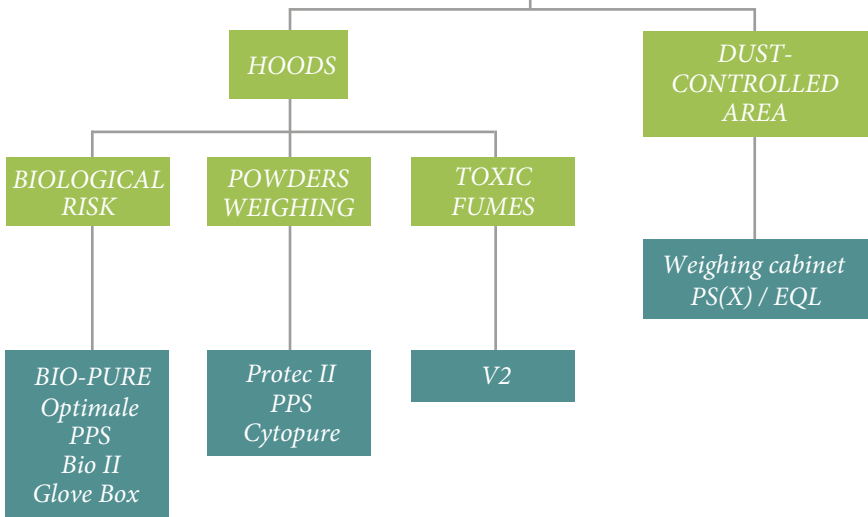

BIO-PURE

Bio-Safety Cabinet Type II

Triple Protection:
Operator
Product
Environment

*Complies with standards
NF EN 12469 & NSF 49*



- ✓ COPLAST Structure
(easily recyclable equipment)
- ✓ 316L Stainless Steel
- ✓ Good ergonomics: inclined and motorized glass, profiled guard vein, side glass
- ✓ Double ventilation with automatic ECM regulation (energy savings)
- ✓ Easy daily maintenance

★ **FLAGSHIP PRODUCT**

Type II microbiological safety cabinets are designed to protect the operator, the product and the environment from airborne contamination.

	BIO-PURE 9		BIO-PURE 12		BIO-PURE 16		BIO-PURE 18	
	Internal	Overall	Internal	Overall	Internal	Overall	Internal	Overall
Width (mm)	915	953	1220	1258	1525	1563	1830	1868
Height (mm)	590 to 620	1400	590 to 620	1400	590 to 620	1400	590 to 620	1400
Depth (mm)	600	790	600	790	600	790	600	790
Power (MIN) (W)	130		190		250		360	
Power (MAX) (W)	800		800		1200		1200	

BIO-PURE

Integrated particle counter

VERSION
MONITORING
GRADE A

Triple Protection:
Operator
Product
Environment

Complies with standards
NF EN 12469 & NSF 49

- ✔ TSI AeroTrak Remote integrated particle counter
- ✔ COPLAST Structure (easily recyclable equipment)
- ✔ 316L Stainless Steel
- ✔ Good ergonomics: inclined and motorized glass, profiled guard vein, side glass
- ✔ Double ventilation with automatic ECM regulation (energy savings)

Type II microbiological safety cabinets with integrated particle counter are intended to protect the operator, the product and the environment from airborne contamination.

The particle counter is a counting probe with sensitivity of 0.1, 0.2, 0.3 or 0.5 μm , with or without integrated pump and flow rate of 0.1 or 1 CFM, Ethernet Modbus communication, wireless, analog (4-20mA), stainless steel housing for a better integration in a clean environment.

	BIO-PURE 9		BIO-PURE 12		BIO-PURE 16		BIO-PURE 18	
	Internal	Overall	Internal	Overall	Internal	Overall	Internal	Overall
Width (mm)	915	953	1220	1258	1525	1563	1830	1868
Height (mm)	590 to 620	1400	590 to 620	1400	590 to 620	1400	590 to 620	1400
Depth (mm)	600	790	600	790	600	790	600	790
Power (MIN) (W)	130		190		250		360	
Power(MAX)(W)	800		800		1200		1200	

OPTIMALE

Bio-Safety Cabinet Type II



Triple Protection:
Operator
Product
Environment

*Complies with standards
NF EN 12469 & NSF 49*

- ✓ Electric window
- ✓ Automatic ECM regulation
- ✓ Maintenance from the front

★ **FLAGSHIP PRODUCT**

Type II microbiological safety cabinets are designed to protect the operator, the product and the environment from airborne contamination.

The Optimale is adapted to the handling of agents that requires biosafety level class 1, 2 or 3.

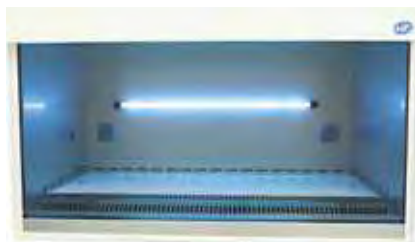

	Optimale 9 NF		Optimale 12 NF		Optimale 16		Optimale 18	
	Internal	Overall	Internal	Overall	Internal	Overall	Internal	Overall
Width (mm)	921	971	1226	1276	1531	1581	1836	1886
Height (mm)	650	1400	650	1400	650	1400	650	1400
Depth (mm)	616	786	616	786	616	786	616	786
Weight(Kg)	190		230		300		350	
Power (W)	1,4		1,4		1,5		1,5	

BIO II

Bio-Safety Cabinet Type II

Triple Protection:
Operator
Product
Environment

*Complies with standards
NF EN 12469 & NSF 49*

- ✓ Compact size
- ✓ Automatic flow regulation ECM
- ✓ Tilted visor

FLAGSHIP PRODUCT



This enclosure is designed for the handling of agents that requires biosafety level class 1, 2 or 3.

It is particularly compact in order to fit in cramped premises.

	BIO II 9		BIO II 12	
	Internal	Overall	Internal	Overall
Width (mm)	919	922	1226	1229
Height (mm)	Internal : 500		Overall : 1080	
Depth (mm)	Internal: 495		Overall : 640	
Weight (Kg)	120		150	
Power (W)	1500			



PPS

Bio-Safety Cabinet Type II



Triple Protection:
Operator
Product
Environment

Complies with standard
NF EN 12469

- ✓ Electric sash window
- ✓ Bag in Bag out system
- ✓ Secure maintenance from the front
- ✓ 3 HEPA filters

★ **FLAGSHIP PRODUCT**

Type II microbiological safety cabinets are designed to protect the operator, the product and the environment from airborne contamination.

The PPS is adapted to the handling of agents that requires biosafety level class 1, 2 or 3.

The PPS is equipped with a marble which allows for precision weighing to 1/100th of a mg.



	PPS 9	PPS 12	PPS 16	PPS 18
Internal Width (mm)	921	1226	1531	1836
Overall Width (mm)	971	1276	1581	1886
Height (mm)	INTERNAL : 650 OVERALL : 1400 WITH BASE: 2200			
Depth (mm)	616 internal		786 overall	
Weight (Kg)	270	330	420	510
Power (kW)	1,4	1,4	1,5	1,5

CYTO-PURE

Bio-Safety Cabinet Type II with 3 filters

Triple Protection:
Operator - Product - Environment

Complies with standard
NF EN 12469

- ✔ COPLAST Structure (easily recyclable equipment)
- ✔ 316L Stainless Steel
- ✔ Good ergonomics: inclined and motorized glass, profiled guard vein, side glass
- ✔ Double ventilation with automatic ECM regulation (energy savings)
- ✔ Secure maintenance from the front (BIBO)
- ✔ 3 HEPA filters



The CYTO-PURE is a microbiological safety cabinet adapted for the handling of agents that require biosafety level class 1, 2 or 3 (LIGHT AND MEDIUM RISK levels), as well as the WEIGHING and HANDLING of C.M.R. products, NOT DECONTAMINABLE OR NON-NEUTRALISABLE.



	CYTO-PURE 9	CYTO-PURE 12	CYTO-PURE 16	CYTO-PURE 18
Internal Width (mm)	915	1220	1524	1828
Overall Width (mm)	964	1276	1573	1884
Height (mm)	580 à 604			
Overall Height (mm)	2220			
Internal Depth (mm)	500			
Overall Depth (mm)	790			
Noise Level	56 dBA		58 dBA	
Nominal Power	130 W	190 W	250 W	360 W
Weight (Kg)	260	300	370	410

PS / MS

Ceiling "Vertical" / Wall "Horizontal" Laminar Flow



Protection:
Product
GMP: Grade A

Complies with standard
ISO 14644

The laminar flow, vertical or horizontal, creates an overpressure zone, to guarantee a clean environment in sterile environment, up to ISO 5 (or more)

- ✓ Custom made
- ✓ Automatic flow rate control ECM
- ✓ Cost effective solution for large volumes



PS(X) / EQL

Weighting booth / Sampling booth



«Bag-in Bag-out»

The laminar flow blowing ceiling, type PS(x) / EQL is particularly suitable for the handling and packaging of allergenic powders, antibiotics, hormones...
Weighing / sampling of raw materials.



Triple Protection:
Operator
Product
Environment

Complies with standard
ISO 14644

- ✓ Custom made
- ✓ Automatic airflow regulation ECM
- ✓ Perfect sterility of the product
- ✓ Integration of screens, printers ...



ADS Laminaire is able to install and to ensure the maintenance of your equipment in France, Europe, in the United States and abroad thanks to its teams of fitters and technicians.



Weighing cabinet for the cosmetics industry - USA

SBM

Clean environment



*Protection:
Product*

*Complies with standard
ISO 14644*



The cleanroom responds to an increasing demand from the industry and research laboratories.

The major asset is to improve air quality without altering the existing infrastructure.

- ✓ Custom-made
- ✓ Capacity for Evolution and Modularity
- ✓ Cost effective



SBM equipped with BSC cabinets (biological research)



SBM entrance with material pass trough

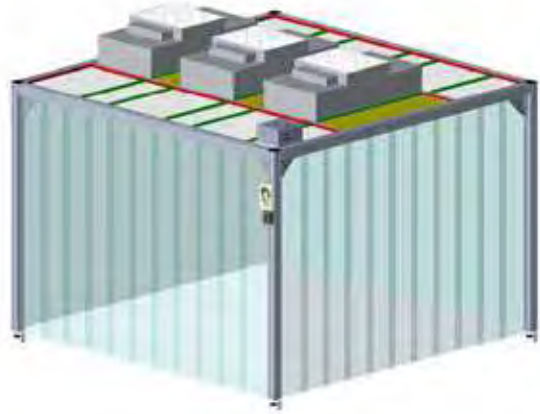
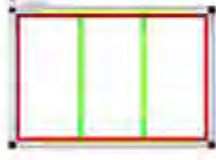
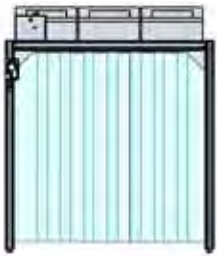

Sketches for approval are delivered before any production.
This procedure guarantees a very quick setup at installation



Download the full documentation

VFL

Vertical Laminar Flow - Class ISO 5

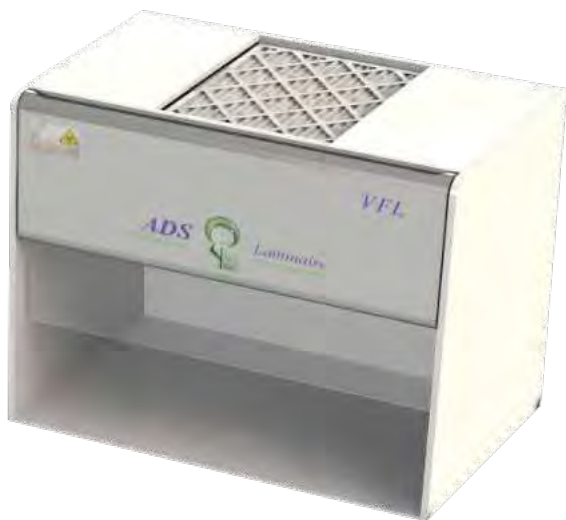

Protection:
Product

Complies with standard
ISO 14644

- ✓ Grande hauteur de travail
- ✓ Solution économique
- ✓ Structure COPLAST/
PVC antistatique

★ **FLAGSHIP PRODUCT**

The VFL is a vertical flow cabinet manufactured in COPLAST. COPLAST is an ultra clean expanded PVC for easy cleaning and decontamination. Its properties allow it to be installed in a cleanroom and the handling of sensitive products. The filtration system based on a self-regulating unit type FANJET guarantees a work in a sterile and clean ISO 5 environment.

	VFL 9		VFL 12		VFL 18	
	Internal	Overall	Internal	Overall	Internal	Overall
Width (mm)	921	959	1226	1263	1834	1872
Height (mm)	INTERNAL : 781		OVERALL : 1250			
Depth (mm)	INTERNAL : 761		OVERALL : 780			
Weight (kg)	60		80		120	
Flow Rate	750		990		1500	

UNIVERS MV/MV

Vertical Laminar Flow - Class ISO 5



Protection:
Product

Complies with standard
ISO 14644

- ✓ Manual regulation
- ✓ Economical solution
- ✓ Glass volume
- ✓ Flip window
- ✓ UV (especially for PCR)

The ISO 5 class hoods are designed to protect the product with a vertical sterile airflow. The enclosure is easy to assemble and can be installed by you.

	Univers MV 9	
	Internal	Overall
Width (mm)	905	925
Height (mm)	Internal : 650 – Overall : 1030	
Depth (mm)	Internal : 592 – Overall : 600	
Weight (Kg)	30	

	MV 6 / 61		MV 9 / 91		MV 12 / 121	
	Internal	Overall	Internal	Overall	Internal	Overall
Width (mm)	623	683	903	968	1208	1278
Height (mm)	Internal : 500			Overall : 965		
Single station Depth (mm)	Internal : 582 - Overall: 611					
Depth of face-to-face station (mm)	800					
Weight (Kg)	36		43		52	

MINISPACE

Vertical Laminar Flow - Class ISO 5



Protection: Product

Complies with standard
ISO 14644

- ✓ Automatic ECM control
- ✓ Flow speed display
- ✓ Full opening of the front panel
- ✓ Transparent working volume
- ✓ Stainless steel worktop
- ✓ LED lighting
- ✓ Ergonomics: side view and inclined front



The MINISPACE consists of a blowing and filtering box, guaranteeing work in a sterile environment. The ISO 5 class hoods are designed to protect the product thanks to a vertical sterile airflow. The MINISPACE is fully automatic, has LED lighting and is suitable for all laboratory configurations.

	MINISPACE	
	Internal	Overall
Width (mm)	780	800
Height (mm)	Internal : 650 – Overall : 935 with base 1766	
Depth (mm)	Internal : 500 – Overall : 510	
Weight (Kg)	50	

IV GEL SPACE

Vertical Laminar Flow - Class ISO 5

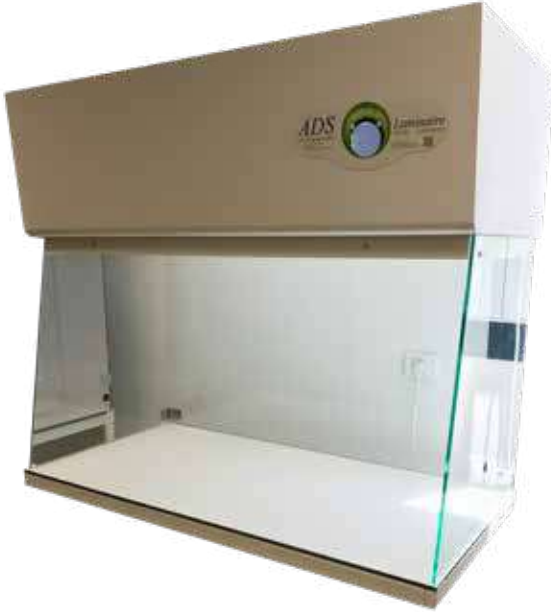

Protection:
Product

Complies with standard
ISO 14644

- ✓ ECM regulation
- ✓ Full front opening
- ✓ Glass volume

The enclosure Type IV GEL consists of a blowing and filtration unit, guaranteeing work in a sterile environment.

The cabinets class ISO 5 are designed to protect the product thanks to a vertical airflow.

The filtration system based on a self-regulating unit type FANJET guarantees a work in sterile and clean environment of ISO 5.



	IV GEL SPACE 9		IV GEL SPACE 12		IV GEL SPACE 16		IV GEL SPACE 18	
	Internal	Overall	Internal	Overall	Internal	Overall	Internal	Overall
Width (mm)	885	930	1190	1223	1556	1573	1792	1825
Height (mm)	Internal : 650				Overall : 1015			
Depth (mm)	Internal : 590				Overall : 600			
Height base(mm)	1870							
Weight (Kg)	80		100		130		150	

V / V1 / V2

Vertical Laminar Flow - Class ISO 5



Protection:
Product

Complies with standard
ISO 14644

- ✔ 3 possible airflow diagrams
- ✔ Automatic regulation ECM
- ✔ Volume in COPLAST

The V is a vertical flow enclosure made of COPLAST.

COPLAST is an ultra clean and smooth expanded PVC, allowing easy cleaning and decontamination. Its properties allow it to be installed in clean rooms and to handle sensitive products.

Optimal protection of the handling, thanks to a class ISO 5 laminar airflow.

Option: inactinic lighting (yellow)

	V 9		V 12		V 16		V 18	
	Internal	Overall	Internal	Overall	Internal	Overall	Internal	Overall
Width (mm)	921	957	1226	1262	1531	1567	1836	1872
Height (mm)	OVERALL: 1370 / 2270 with base							
Width (mm)	INTERNAL: 658				OVERALL: 766			

OPTIGEL

Horizontal Laminar Flow - Class ISO 5



Protection:
Product

Complies with standard
ISO 14644

Optigel type hoods are designed to protect the product thanks to a class ISO 5 horizontal laminar airflow.

- ✔ Opens completely
- ✔ Automatic Regulation ECM
- ✔ Plexiglass side windows
- ✔ Stainless steel work surface

✚ **FLAGSHIP PRODUCT**

	OPTIGEL 9		OPTIGEL 12		OPTIGEL 18	
	Internal	Overall	Internal	Overall	Internal	Overall
Width (mm)	910	945	1225	1245	1670 / 1820	1695 / 1845
Height (mm)	INTERNAL: 572-620				OVERALL: 813	
Depth (mm)	INTERNAL: 570				OVERALL: 916	
Height base (mm)	1740					
Weight (kg)	80		100		150	

OPTIMUM

Horizontal Laminar Flow - Class ISO 5



Protection:
Product

Complies with standard
ISO 14644

- ✓ Automatic regulation ECM
- ✓ Electric sash curtain
- ✓ Volume in COPLAST
- ✓ 12 available sizes

The cabinets type Optimum are designed to protect the product, thanks to a class ISO 5 horizontal laminar airflow.
There are 12 models of Optimum.

The Optimum is made of COPLAST expanded PVC ultra clean and smooth, allowing an easy cleaning and decontamination. Its properties allow it to be installed in clean rooms and allow the handling of sensitive products.

		OPTIMUM											
		9	12	16	18	91	121	161	181	92	122	162	182
Width (mm)	Internal	921	1226	1531	1836	921	1226	1531	1836	921	1226	1531	1836
	Overall	959	1264	1569	1874	959	1264	1569	1874	959	1264	1569	1874
Height (mm)	Internal	616				768				921			
	Overall	1159				1300				1464			

BCS

Extraction Fume Hood



*New / Unique
Inclined window
for better comfort*

Protection:
Operator

*Complies with standard
EN 14175*

- ✓ Inclined sash window
- ✓ Control panel Type ECRO
- ✓ COPLAST Structure
- ✓ No maintenance
- ✓ Vacuum cabinet

The BCS is an extraction fume hood made of COPLAST. The fume hoods ensure the protection of the users and their environment thanks to a depression of the working volume towards the outside.

Designed with non-particulate and chemical resistant materials, they can be integrated into controlled atmosphere areas. In addition, the inclined window provides more comfort.

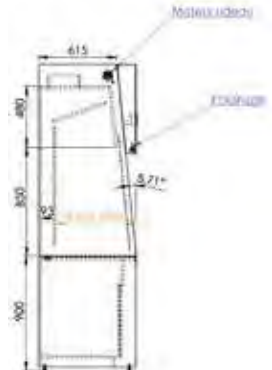

	BC 9		BC 12		BC 16		BC 18	
	Internal	Overall	Internal	Overall	Internal	Overall	Internal	Overall
Width	921	959	1226	1264	1531	1569	1836	1874
Height	INTERNAL: 1025 to 1130 OVERALL: 1500 (without base)							
Depth	INTERNAL: 660 OVERALL: 765							

T

Extraction Station



Protection: Operator

- ✓ No Maintenance
- ✓ Custom-made
- ✓ COPLAST Structure

TPL version with ventilated cupboard

The T is designed to protect the users and their surrounding environment by means of an exhaust system. Made of non-particle-generating materials, it can be installed directly in clean rooms. The optimization of the dimensions makes it possible for it to be integrated in any type of laboratory, even low ceiling ones.

	T 81		T 82		T 83		T 84	
	Internal	Overall	Internal	Overall	Internal	Overall	Internal	Overall
Width (mm)	784	800	784	800	1204	1220	1484	1500
Height (mm)	267	275	Internal : 642		OVERALL : 650			
Depth (mm)	Internal : 340				OVERALL : 590			
Diameter (mm)	125		160		200		200	
Flow rate (m ³ /h)	300		700		1000		1200	

FANJET

Self-contained Filtration Box - FFU



Protection:
Product

Complies with standard
ISO 14644

The air is sucked through a G3 pre-filter by a powerful and quiet motor-driven fan.

The airflow is filtered by a HEPA filter (ULPA option). The MONOBLOC system guarantees the integrity of the entire box.

The automatic flow control makes it possible to compensate for the clogging of the absolute filter and thus to ensure a constant air flow.

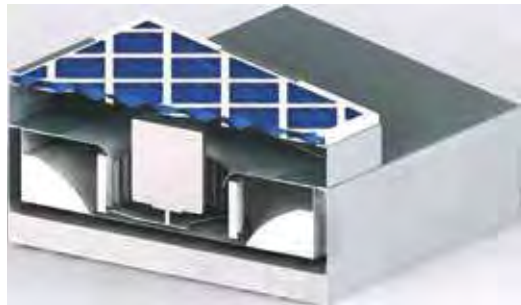
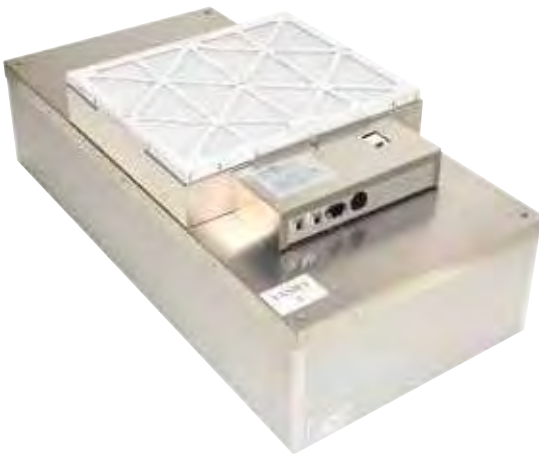

- ✓ Automatic ECM Regulation
- ✓ Fluid Seal Filter
- ✓ Maintenance from below

- ✓ Automatic ECM Regulation
- ✓ Fanjet 6/6; 6/9; 6/12; 12/12



FLOW'R-PURE

Protection against viruses and pollens

ultra-filtration and UV sterilization - HEPA 99.999% at 0.3 μm

Applications

Stand-alone device, a simple 230V mono socket is sufficient.

Thanks to our 50 years of experience and our mastery of airborne contamination, the ADS LAMINAIRE teams were able to develop an ultra-filtration system in record time and decontamination of ambient air adapted to fight against the pandemic. Depending on the model chosen, the filtration capacity will vary from 20m² to over 100m².

- ✔ Classrooms / refectories
- ✔ Medical offices
- ✔ Examination rooms
- ✔ Premises open to the public (shops)
- ✔ Housing / Retirement home
- ✔ Concert halls / Cinemas / Theaters

Operating principle

The air is drawn through a grid into a G4 pre-filter (90% efficiency for 10μm particles) which stops dust and other medium sized particles. It is then guided to the filtration box (absolute filter) type HEPA H14 with an efficiency greater than 99.999% @0.3μm. A germicidal UV tube (254 nanometers) will continuously sterilize the filtration plenum in which all fine particles carrying possible pathogenic micro-organisms will have been trapped.

This device is equipped with wheels, allowing the scrubber to be moved easily.



EPURE 6/12

Technical Specifications

	Width (mm)	Height (mm)	Depth (mm)	Speed Regulation	Flow Rate m ³ /h	Activated Carbon	UV
FLOW'R-PURE 36	305	610	250	600-1200	300	Option	Included
FLOW'R-PURE 66	605	1300	350	Automatic	600-1200	Option	Option

CONVOYAIR

Modular box with laminar flow



Protection:
Product

Complies with standard
ISO 14644

Laminar flow box designed to be integrated into customized structures.
Structure 100% Stainless steel 304 L (option 316).

- ✓ Custom-made
- ✓ Economic
- ✓ Multiple configurations
- ✓ Freestanding



Configuration Examples



Option:
Lighting
Aluminium base
Stainless Steel Base

	CONVOYAIR CX 6/9		CONVOYAIR CX 6/12		CONVOYAIR CX 9/9	
	Internal	Overall	Internal	Overall	Internal	Overall
Length (mm)	915	1055	1220	1360	915	1055
Width (mm)	610	680	610	680	915	1055
Box Height (mm)	605		605		605	
Weight (Kg)	60		80		80	

S / SP

Mobile Ultrafiltered Laminar Flow -Class ISO 5



Protection:
Product

5a_ b/Wi [fZ eS` VScV
ISO 14644

- ✓ Mobile
- ✓ Allows to put premise in positive pressure
- ✓ Ultra-filtered air

The S-type units are designed to put an ultra-filtered room air in positive pressure in order to reduce their dusting rate very effectively and very simply.

The integrated blower in the wall blows an ultra-filtered air inside the room. This airflow creates a barrier which prevents external particles from entering the room. This ensures the controlled environment thanks to air renewal in the room. This ensures the control of the dust level and the air renewal rate of the room.

	S 3/3	S 3/6	S 3/9	S 3/12	S 6/6	S 6/9	S 6/12
Width (mm)	350	350	350	350	650	650	1260
Height (mm)	350	650	950	1260	650	950	650
Depth (mm)	400	400	400	400	630	630	630
Flow rate (m3/h)	150	300	450	600	600	900	1200

PROTEC I

Horizontal suction station / Weighing station

Double Protection:
*Operator
Environment*

- ✓ COPLAST Structure
- ✓ Automatic or manual Regulation
- ✓ Glass Volume



The negative pressure hoods are designed to protect the users and their close environment from any aero-contamination, thanks to a horizontal aspiration system and absolute HEPA filtration.

The PROTEC I is particularly recommended for the handling of powders, noxious products, pulverizers...

PROTEC I can be installed on a bench or on a base.

	PROTEC 81		PROTEC 12		PROTEC 161	
	Internal	Overall	Internal	Overall	Internal	Overall
Width (mm)	775	825	1210	1260	1515	1565
Height (mm)	Internal : 662			OVERALL 1150		
Depth (mm)	Internal : 520			OVERALL : 880		
Weight (kg)	120		150		180	
Flow rate (m3/h)	900		1400		1700	

POWDERJET

Horizontal safety bench / Weighing station



Double Protection: Operator Environment

- ✓ Full Opening
- ✓ ECM regulation
- ✓ Cost-effective solution
- ✓ Stainless Steel worktop

★ **FLAGSHIP PRODUCT**

The negative pressure hoods are designed to protect the users and their close environment from any aero-contamination, thanks to a horizontal suction system and absolute HEPA filtration.

The POWDERJET is particularly recommended for the handling of powders, noxious products, pulverizers...

	POWDERJET 9		POWDERJET 12		POWDERJET 18	
	Internal	Overall	Internal	Overall	Internal	Overall
Width (mm)	920	925	1225	1250	1820	1840
Height (mm)	Internal : 550		OVERALL : 813			
Depth (mm)	Internal : 550		OVERALL : 911			
Height with base (mm)	1740					
Weight (kg)	80		100		150	

MINIPURE

Recirculating Fume Hood
Adsorption on activated carbon
filter

CONTROLLED BY
INDEPENDENT
LABORATORY



Double Protection: Operator Environment

- ✓ Automatic ECM Regulation
- ✓ Display of flow speeds
- ✓ Full opening of the front panel
- ✓ Transparent working volume
- ✓ Stainless steel work surface
- ✓ LED lighting
- ✓ Ergonomics: side view and inclined front

The recirculating fume hood type MINIPURE is designed to protect the users and their close environment from volatile, noxious or malodorous products thanks to a vertical suction system on activated carbon.

The MINIPURE is fully automatic, has LED lighting and is suitable for all laboratory configurations.



MINIPURE		
	Internal	Overall
Width (mm)	780	800
Height (mm)	Internal : 650 – Overall : 935 on base: 1766	
Depth (mm)	Internal : 500 – Overall : 510	
Weight (Kg)	50	

C-PURE

Recirculating Fume Hood

CONTROLLED BY
INDEPENDENT
LABORATORY



Double Protection:
*Operator
Environment*

*Compliant with standard
NFX 15211 : 2009*

- ✓ Structure in Polycarbonate and Painted steel
- ✓ 2-buttons Control Panel
- ✓ Easy Maintenance
- ✓ Holding Tank in PPH

★ **FLAGSHIP PRODUCT**

The C-PURE Recirculating Fume Hood is intended for the protection of users handling dangerous substances from Category 1, 2 and 3 (CMR) and products which have an exposure limit value (ELV).

- Activated Carbon Filter
- HEPA Filter
- Pre-filter (recommended option when handling powders)



	C-PURE 9		C-PURE 12		C-PURE 16	
	Internal	Overall	Internal	Overall	Internal	Overall
Width (mm)	966	1000	1166	1200	1566	1600
Height (mm)	INTERNAL : 855			OVERALL : 1150		
Depth (mm)	INTERNAL : 520			OVERALL : 577		
Weight (Kg)	80		100		120	
Flow Rate (m3/h)				250		

UNIVERS MAV

Recirculating Fume Hood
Adsorption on activated carbon filter



Double Protection: Operator Environment

- ✓ Self-assembly structure
- ✓ Manual regulation
- ✓ Glass volume
- ✓ Tilting frontal window



The Recirculating Fume Hood type UNIVERS MAV is intended to protect the users and their environment close to volatile, harmful or malodorous products thanks to a system of vertical suction on activated carbon.

	Univers MAV 6		Univers MAV 9	
	Internal	Overall	Internal	Overall
Width (mm)	600	620	905	925
Height (mm)	650	1030	650	1050
Depth (mm)	592	600	592	600
Weight (Kg)	25		30	

	MAV 6 / 61		MAV 9 / 91		MAV 12 / 121	
	Internal	Overall	Internal	Overall	Internal	Overall
Width (mm)	623	683	903	968	1208	1278
Height (mm)	Internal : 500			Overall : 965		
Single station depth (mm)	Internal : 582 - Overall: 611					
Depth of face-to-face station (mm)	800					
Weight (Kg)	36		43		52	

AD

Recirculating Fume Hood Horizontal Aspiration

Double Protection: *Operator Environment*



- ✓ COPLAST Structure
- ✓ Automatic or Manual regulation
- ✓ Large working area
- ✓ Active carbon filter with high absorption capacity

The AD-type recirculating Fume Hood is designed to protect the users and their surrounding environment from volatile, harmful or malodorous products thanks to a horizontal suction system on activated carbon.

AD is recommended for handling chemicals such as acid, alcohol, solvents, etc.

	AD 8		AD 12		AD 16	
	Internal	Overall	Internal	Overall	Internal	Overall
Width (mm)	775	825	1210	1260	1515	1565
Height (mm)	INTERNAL: 640		OVERALL: 1150			
Depth (mm)	INTERNAL: 520		OVERALL: 880			
Total weight (kg)	80		120		150	

LAM

Filtration Fume Hood Vertical Suction



Double Protection: *Operator Environment*

- ✓ COPLAST Structure
- ✓ Absolute HEPA filter and/or Activated Carbon
- ✓ Foldable visor (made of safety glass)
- ✓ Automatic regulation

The Fume Hoods are designed to protect the users and their close environment from any aerocontamination thanks to a system of vertical suction and absolute filtration and/or activated carbon. The LAM are particularly recommended for handling pathogenic germs and/or handling of chemicals (acids, solvents, alcohol).

The LAM can be placed on a bench or on a base.

	LAM 6		LAM 9		LAM 12	
	Internal	Overall	Internal	Overall	Internal	Overall
Width (mm)	625	663	930	868	1235	1273
Height (mm)	INTERNAL: 547 OVERALL: 1380 UNDER FLOW: 723					
Depth (mm)	INTERNAL: 681 OVERALL: 726					
Total Weight (kg)	90		120		150	

AIR SHOWER

Clean environment access / Clean room



Double Protection: *Operator Environment*

- ✓ COPLAST custom-made structure
- ✓ Programmable robot
- ✓ From ISO 8 to ISO 5
- ✓ Option 304L Stainless Steel
- ✓ Stainless steel nozzles on the sides and ceiling (adjustable)
- ✓ Air velocity from 17 to 25 m/s
- ✓ Lighting

Air showers are used before entering a clean environment or clean room, they ensure a complete dedusting of the outfits.

This process can also decontaminate users who have manipulated powders at the exit of production zones.



GLOVE BOX

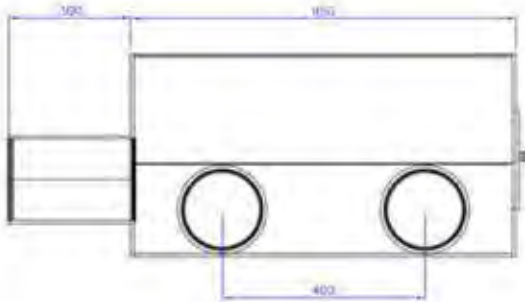

Protection: Operator Product

- ✔ Custom structure with option
- ✔ Latex / Neoprene / Butyl Gloves
- ✔ Pass-through equipment



The glove box can isolate critical products from oxydation.

The structure of methyl methacrylate gives high resistance to corrosive agents and offers total visibility.

The structure can be made of stainless steel or COPLAST.

Note :

Realization of a custom made structure according to special request .

- Nitrogen sweep
- Flowmeter
- Pass-through for material introduction - in / out, trash.

EXHAUST FANS

Air Extraction for chemicals (acids, solvents)



These fans are designed for the aeraulic extraction of chemical hoods, fume hoods, etc. They are particularly adapted to the extraction of corrosive fumes.

Ref.	Technical Data			
	Power kW	Rotation speed tr/min	Connection diameter	Weight kg
ADS 202	0.18	2750	Ø 160	9
ADS 254	0.12	1370	Ø 200	10
ADS 242	0.37	2800		13
ADS 314	0.25	1400	Ø 250	19
ADS 312	1.50	2850		26
ADS 354	0.37	1400	Ø 280	23
ADS 352	2.20	2870		32
ADS 404	0.55	1410	Ø 315	33
ADS 402	5.5	2850		33
ADS 454	1.10	1410	Ø 355	40
ADS 452	3.0	2860	Ø 355	37

ATEX Option

DRY / STORAGE BOX AND FURNITURE

Storage and furniture in clean environment



Protection : Product

- ✓ Custom structure with options
- ✓ COPLAST / Stainless steel / GLASS / PLEXIGLAS
- ✓ Made in France

The boxes are designed to store samples in a dust-free environment or in a neutral environment (gas flushing).

Features:

- Methyl methacrylate structure
- Door with neoprene seal
- Quarter-turn type closure
- 1 shelf per compartment

TYPE	HEIGHT	WIDTH	DEPTH
B1	300	300	300
B2	500	300	300
B3	750	300	300



Options:

- Laminated wood structure
- Inactinic structure, antistatic
- Gas passage, valve
- Flowmeter



Pass-through version

The SAS pass-throughs allow the introduction of material directly into the clean room.
Standard dimensions: 600 x 600 x 600 mm - Option: door locking (automatic)

Several worktop heights available options:
850mm, 900mm, 950mm.

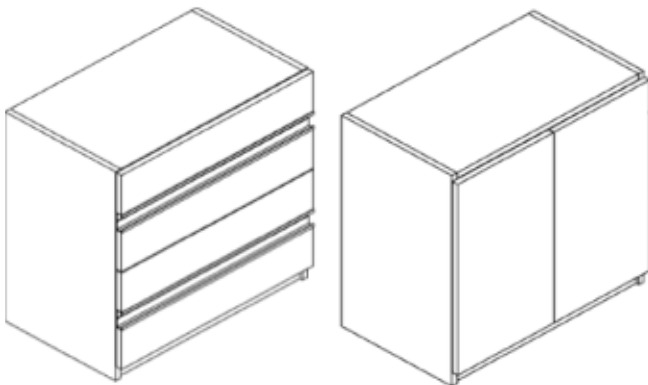
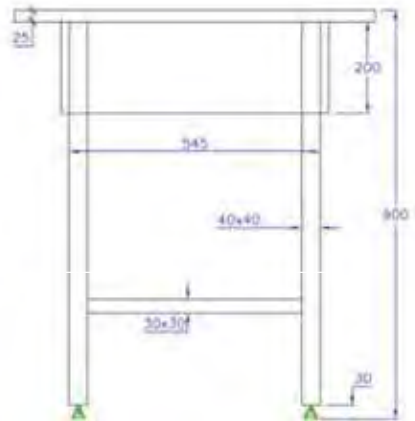
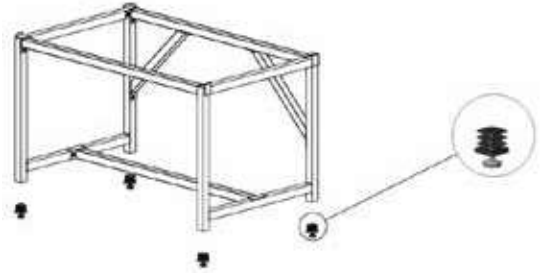
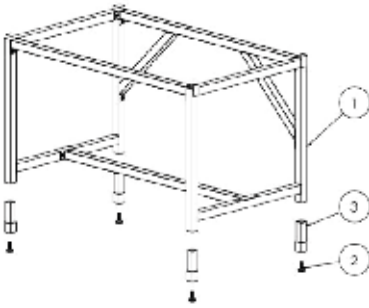

We offer the following furniture:

(Photo on request)

- Workbenches
- Shelves
- Lockers
- Shoe benches
- Closets
- Lockers
- Clothes racks

LED TILES 40 W

Extra-flat flush mount led tiles



- ✔ SII approval
- ✔ High quality LED
- ✔ Light power is higher than 4X14W.
- ✔ Low thickness - 11mm.
- ✔ International standard LIFUD external driver
- ✔ Suitable for suspended ceiling.
- ✔ Includes hanging accessories.
- ✔ IRC 85.
- ✔ Spacers can be purchased separately for conversion to 605*605.
- ✔ Variable intensity.

Light Efficiency	Catalog reference
Hanger accessories for 595*595 tile	17900300
Spring kit for 595*595 tile	17900306
Spacer for 595*595 to 605*605 tile	17900309
595*595 tile surface mount adapter	17900304

Light Efficiency	Color temperature	Description	Catalog reference
2900 lm	3000 K	Led Panel 40W 59*59 Warm White	17840183
3000 lm	4000 K	Led Panel 40W 59*59 Neutral White	17840184
3150 lm	6000 K	Led Panel 40W 59*59 Cold White	17840185

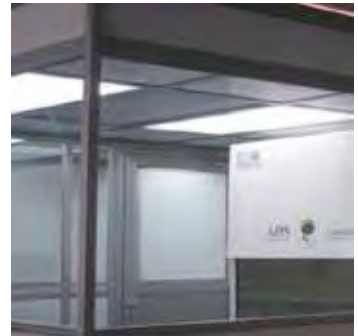

CONSUMABLES / DISPOSABLES

Garnment / Wipes / SWABS / MATS

Consumables and Disposables are included in the wide range of clean room products we can offer to our customers and include garments, wipes, swabs, mats etc.

ADS LAMINAIRE has chosen the best suppliers who have been manufacturing industrial wipes and who have specialized since 1970 in the field of ultra cleanliness.

GARNMENTS



SWABS



WIPES



STICKY MATS



A fully detailed catalogue of consumables and disposable is available on request

FLOWAIR FILTERS

Filters

Design and production of a complete range of air filters.

With our fifty years of experience, we wish to put our competence and know-how at your service.

Our filters are perfectly suited to the most demanding applications of air treatment systems in laboratories, manufacturing units in the electronics, pharmaceutical and food industries...

We give you the benefit of a manufacturer's cost.

Our experience allows us to offer you all types of standard and custom filters.

We put at your disposal, in our site of Aulnay-Sous-Bois (near CDG Paris Airport), a large inventory of 3000 filters, in standard format and of all efficiencies.

Finally, thanks to its design office and its manufacturing units, Flow Air Filters is able to meet all your expectations for non-standard products.



AFTER SALES SERVICE

Maintenance / Control & Validation

Speed control

Equipment: Hot Wire Anemometer

Objectives: To carry out a mapping of the speeds and to check the laminarity of the airflow.

Measure frontal airflow velocity. Determine flow rates and hourly turnover rate.

Equipment to be controlled: Laminar flow cabinets, biosafety cabinets, clean rooms, blowing ceilings, fume hoods, recirculating fume hoods.

Smoke test: With Smoke tube.

Particle counting

Used Equipment: Laser particle counter

Objectives: To determine the dust class of an area.

Demonstrate leakage (by scanning filters) or contaminated areas.

Equipment to be controlled: Laminar flow cabinets, biosafety cabinets, Clean rooms, Blowing ceilings.

Applicable standards: ISO 14644, GMP

Other controls (please contact us)

- Qualifications (IQ/OQ/PQ)
- Sound level
- LIGHT intensity
- Bacteriological control
- Temperature / Hygrometry
- Saturation test of activated charcoal filters - SF6 gas confinement test

Spare parts

Quick response to requests or needs due to the large stock available in our warehouse in Aulnay Sous Bois.

- 3000 Absolute filters (standard dimensions)
- 10000 Prefilters
- 500 Fans
- 500 electronic cards
- Various

Emery Integrity Test (option):

Equipment: Spectrophotometer Aerosol Generator (product used: Emery 3004)

Objectives: leak test of the filters by looking for leaks on the filter media and the frame.

Material to be controlled: Laminar flow cabinets, biosafety cabinets, Clean rooms, Blowing ceilings.

Current standards: ISO 14644, EN 12469

Maintenance

- Change of filters (Absolute, pre-filters, activated carbon)
- Adjustment, compliance
- Decontamination (mandatory for any work on a station used for the manipulation of pathogenic germs)
- Trash of the filters for destruction with issuance of a neutralization certificate
- Various repairs, parts change - Technicians specializing in laminar flow and clean rooms
- Detailed control reports
- Calibration certificates for all our measuring devices.



TINY S Smoke Generator



VENTUM Decontamination Kit



References	Description	Log	Use examples	Recommended contact time
VOT-6-02	Diffusion One-Touch Décontamination Pouches - 2 m ³	Log 6	•Bio-safety cabinets •Laminar Flow •Incubators	2 hours
VOT-6-05	Poches Diffusion One-Touch décontamination - 5 m ³	Log 6	• SAS •Weighting Booths	2 hours
VOT-6-10	Poches Diffusion One-Touch décontamination - 10 m ³	Log 6	•Cleanrooms • SAS	2 hours
VOT-6-25	Poches Diffusion One-Touch décontamination - 25 m ³	Log 6	•Operating rooms •Cleanrooms •Containment Laboratories	2 hours
VOT-5-02	Poches Diffusion One-Touch décontamination - 2 m ³	Log 5	•Incubators •Sanitary Facilities	1 h 30
VOT-5-05	Poches Diffusion One-Touch décontamination - 5 m ³	Log 5	• SAS •Cleanrooms •Sanitary Facilities	1 h 30
VOT-5-10	Poches Diffusion One-Touch décontamination - 10 m ³	Log 5	•Cleanrooms • Sanitary Facilities	1 h 30
VOT-5-25	Poches Diffusion One-Touch décontamination - 25 m ³	Log 5	• Cleanrooms •Laboratories • Sanitary Facilities	1 h 30
VOT-4-10	Poches Diffusion One-Touch décontamination - 10 m ³	Log 4	• Ambulances • SAMU • Cleanrooms • Food • Disease Chambers • Infectious	15 min
VGN-4-100	Poches Diffusion Gun décontamination - 50-100 m ³	Log 4	• Ambulances • SAMU • Disease Chambers • infectious	15 min
VGN-3-100	Poches Diffusion Gun décontamination - 50-100 m ³	Log 3	• VSL (Light medical vehicles) • Dental Offices • Medical Offices • Disease Chambers	10 min
VGN-2-100	Poches Diffusion Gun décontamination - 50-100 m ³	Log 2	• transportation - Planes - Cruises - Cars - Trains, bus, subway... •Hospitality & living spaces...	5 min

All of our hoods are tested in our laboratory before delivery



Controls carried out at the laboratory

Speed, Flowrate, Particles, Sealing, Flow, lighting level,
noise level, traceability

► **ADS Laminaire**
Air Dépoussiéré Stérile Laminaire



ADS LAMINAIRE FRANCE

34 Rue Maurice de Broglie
ZI Les Mardelles
93600 Aulnay-Sous-Bois | France
Tél : +33 (0)1 48 17 85 10
Fax : +33 (0)1 48 17 85 11

 info@adslaminaire.com

 www.adslaminaire.com

ADS AIR FILTERS USA

47 W Polk Street
Suite 324
CHICAGO, IL 60605

 marina.cassin@adslaminaire.com
clara.guiraud@adslaminaire.com

 www.adslaminaire-usa.com

